

MINIMUM SPECIFICATION FOR CONCRETE WALLED SILOS

The receiving of this specification does not imply approval of a grant application. However, if written approval is issued, then this specification becomes part of the contract between the applicant and the Department of Agriculture and Food.

This is a minimum specification. Where the word “SHALL” is used, then that standard (at least) **must** be followed in grant-aided buildings. Where a procedure is “RECOMMENDED”, this is advice only on good practice.

Note that all references to other Department Specifications are to the current edition of that specification [available on the Department of Agriculture and Food Website (www.agriculture.gov.ie) under Farm buildings]. Similarly, references to Standards are to the current edition of the Irish, British or European Standard, as appropriate.

1. SAFETY

1.1 Responsibility for Safety

Applicants are reminded that they have a duty under the Safety, Health, and Welfare at Work Act 1989 to provide a safe working environment on the farm, including farm buildings, for all people who may work on that farm. There is a further duty to ensure that any contractor, or person hired to do building work, provides and/or works in a safe environment during construction.

1.2 Safety during Construction

Farmer/Applicant Responsibility: Please note that neither the Minister nor any official of the Department shall be in any way liable for any damage, loss or injury to persons, animals or property in the event of any occurrence related to the development and the applicant shall fully indemnify the Minister or any official of the Minister in relation to any such damage, loss or injury howsoever occurring during the development works.

Dangers: Where the applicant/farmer is undertaking any part of the above work, it is his/her responsibility to seek competent advice and to undertake all temporary work required to ensure the stability of excavations, superstructure, stanchion foundations, wall foundations, to guard against possible wind damage and to avoid any other foreseeable risk. It is also his/her responsibility to ensure that any drains, springs or surface water are diverted away from the works.

Power lines: Farm buildings shall not be constructed under or nearer than 10m to an overhead power supply. If advice is required, or if power lines need to be diverted, it is the applicant’s responsibility to contact, in writing, the local ESB supervisor before construction commences and then to follow the ESB conditions.

Danger to children: It is the applicants responsibility to prevent children from playing or spending time in the vicinity of any construction work.

2. CONCRETE SPECIFICATION

2.1 Certificates

Concrete shall be produced in an audited plant only: It shall not be produced on site.

A numbered certificate, signed and stamped, shall be required for all concrete delivered to site. The certificate, the "Concrete Manufacturers' Specification Certificate", is produced in triplicate. **The top certificate, printed on light blue paper, shall be retained by the applicant** and given to and retained by the local AES Office of the Department of Agriculture for inspection upon completion of the works.

2.2 Concrete

For walled silos, silage aprons, silo channels and **purpose-built** silage effluent tanks, concrete shall be purchased on the basis of a characteristic 28 day crushing strength of 40N/mm². Minimum cement content shall be 350 kg/m³. The slump of unplasticised concrete shall not exceed 90mm. Maximum aggregate size shall be 20mm.

The concrete shall be ordered by requesting '40N concrete to be certified to the grant-aid standard of the Department of Agriculture and Food'.

If the Concrete Supplier requires further information the following shall be quoted to them:

- The concrete is to be to I.S. EN 206-1:2002: Strength Class: C32/40, 350 kg cement, maximum water cement ratio of 0.50, Exposure classes: XA3, XC4 (20 year life), Slump class: S2 (unplasticised), maximum aggregate size 20mm.

If plasticised concrete is desired, the slump class shall not exceed S3.

Polypropylene fibres may be incorporated into the concrete mix to improve the properties of concrete. Only fibres which have been tested and approved by National or European approval authorities may be used. The use of fibres helps to reduce plastic cracking and improve surface durability but they are not a substitute for structural reinforcement. Fibres shall be used in strict compliance with manufacturer's instructions and shall only be added at the concrete manufacturing plant. The concrete certificate (Clause 2.1), shall clearly show the amount and type of fibre added. The mix design, compacting, and curing of fibre concrete is the same as concrete without fibre.

Note: The resistance of concrete to acid attack by silage effluent depends on a high cement content concrete as specified, on the use of the least amount of water to produce a stiff but workable mix, which is thoroughly compacted and subsequently properly cured as specified (see Clauses 2.5 and 18). Plasticisers or superplasticisers may be incorporated in the concrete, particularly in warm weather, to improve workability. Under no circumstances shall additional water be added to the concrete to change the workability. Any additives used shall comply with British Standard 5075; they shall be used strictly in accordance with manufacturer instructions and shall be added at the ready-mix plant. Where an additive is used it shall be certified on the invoice by the ready-mix supplier that it was used and complies with BS 5075.

2.3 Materials

Cement used in concrete and concrete products shall be certified to IS EN 197-1, and shall bear the Irish Standard Mark, or shall be certified by NSAI to be equivalent to IS EN 197-1. All aggregates shall be to IS 5 1990. Plasticisers and other admixtures shall be to EN 934. All admixtures shall be used in strict accordance with manufacturer's instructions, and shall be added only by the concrete-mix manufacturer.

2.4 Tests

The Department reserves the right to require that concrete should be tested in accordance with BS1881, and that installed reinforcement may be checked by electronic or other means.

2.5 Compaction of Concrete

All concrete shall be compacted by either vibrating screed or poker vibrator depending upon the position of the concrete. Poor compaction leads to entrapped air, which will weaken the concrete and may cause premature failure. All concrete can be easily placed and compacted when using a vibrating screed or poker vibrator which helps ensure the concrete achieves its full strength.

2.6 Curing of Concrete

All concrete shall be cured by keeping it thoroughly moist for at least seven days. Wetted floor slabs and tank walls shall be protected by polythene sheeting, kept securely in place. Alternatively proprietary curing agents may be used in accordance with manufacturer's instructions. When frost is a danger, straw bales shall be placed over the polythene on slabs. Concrete shall be at least 28 days old before being subjected to full load.

No silage should be placed on the slab for 28 days after concrete has been poured.

Note: Uncured concrete is the chief cause of concrete failure in silage slabs.

3. Site

Walled silos shall be sited on firm/solid ground that is not subject to flooding. Sites on made up ground, i.e. filled ground, or where differential settlement is likely to occur leading to structural cracks, shall be avoided.

The site shall be carefully selected having regard to existing and proposed animal housing, ease of access and possible future extensions. Extreme care shall be exercised to avoid pollution to rivers, streams and ground water. All surface water draining on to the site from higher ground or any under-drainage passing through the site shall be intercepted and diverted.

As a general guide, the site should be located not less than 50m from any waterbody in the case of new farmyards, and not less than 10m in the case of extensions/modifications to an existing facility. The minimum distance between a walled silo and a public/private water supply source, either surface or ground, shall be 60m. In vulnerable situations this distance shall be increased up to 300m.

4. Site Preparation and Placing of Hardcore under Concrete Slab

All top soil and soft material shall be excavated to a minimum depth of 150mm, or down to solid stratum, and the excavated material shall be removed from site to a suitable area. Hardcore shall be compacted in 150mm layers using a suitable vibrating or heavy roller. Consolidation with wheeled or tracked plant is not adequate. The hardcore base shall be finished to a minimum fall of 1:60, blinded over with sand or lean concrete mix.

5. Foundations for Silo Walls

Foundations for silo wall footings shall be excavated to a minimum depth of 600mm below the original ground level, or to such further depth necessary to reach firm strata to ensure stability of structure. The excavation shall be taken out neatly so as to produce clean-cut, vertical sides against which concrete for the footings shall be poured. In loose non-cohesive soils further excavation may be required to deepen the footing near the toe in order to produce increased resistance to sideways slip, see Fig.1. On completion of the excavation a 50mm (min) layer of blinding concrete, shall be placed on the bottom of the excavation.

6. Foundations for silo floor, apron and front channel

The Foundation shall consist of thoroughly compacted hardcore, and around the apron shall extended a minimum of 300mm in each direction beyond the edge of the finished apron. Hardcore placed in excavated soft areas or on made-up ground shall be compacted in 150mm layers using a suitable vibrating or heavy roller. Special care shall be exercised in compacting the edges of the slab, and under the proposed channels. Where channels are constructed the level of the foundation shall be lowered in accordance with Figs. 5, 6, 7. All hardcores shall be blinded over by fine sand or a 50mm layer of blinding concrete finished smooth.

A 1000 gauge polythene membrane shall be laid on the finished hardcore with 600mm overlaps. The overlaps shall be sealed with suitable adhesive tape. The polythene shall be brought up on the inside of the timber or steel formers.

7. Footings

Reinforcing shall be placed as set out in Clause 8. Concrete shall be poured to complete a footing in a single day. A key shall be formed in the footing at the centre of the proposed wall by using a splayed oiled timber runner temporarily fixed in the freshly poured concrete and withdrawn before final set. The key shall be as shown in Fig. 2. The key shall not be formed by removing or hacking out recently poured concrete. Alternatively a patent water-bar shall be fixed horizontally along the footing at the centre of the proposed wall.

8. Walls

The top of all cast-in-situ walls shall be 225mm thick, with a batter of 1:12 on the inside face, or 1:12 on both faces where a wall forms a common wall of a double silo and a batter of 1:12 on the rear wall. In the case of a common wall, reinforcing shall

be doubled and placed 50mm behind each face, but the top thickness may be reduced to 150mm.

Walls shall be reinforced as per clause 9.

9. Steel Reinforcing

9.1 Unroofed walled silo

Steel reinforcement shall consist of high yield steel with a ribbed finish in accordance with BS 4661, as amended or mild steel in accordance with BS 4449. Reinforcing bars shall be cut and bent to the required shapes. Bars shall not be straightened and re-bent. Reinforcing shall be placed as shown in Fig. 1. The minimum cover of 50mm shall be achieved and maintained by the use of spacer blocks. All junctions of bars shall be secured with tying wire of not less than 1.6mm diameter (16 SWG) or by tack welding. Where the required lengths of bars exceed the length supplied, a lapped joint shall be adopted, the overlap length being not less than 60 times the bar diameter. Buttwelding of bars to extend their length is not permissible. All steel shall be free from mill scale and heavy deposits of rust.

Table 1, shows the reinforcing minima for unroofed silo walls not higher than 2.1m and not subjected to compaction by vehicles other than normal farm tractors.

Table 1

Wall Height (H*)	Vertical Steel (High Yield)	Horizontal Steel
up to 2.1m	12mm @ 200mm centres	12mm @ 400mm centres

*Height in all cases is the difference between top of wall and top of footing.

Table 2 shows reinforcing minima for unroofed silo walls subject to extra heavy machinery, and for normal farm tractors where height exceeds 2.1m.

Table 2

Wall Height (H)	Vertical Steel (High Yield)	Vertical Steel (Mild)
Up to 2.1m	16mm @ 250mm centres or 12mm @ 150mm centres	16mm @ 175mm centres
2.4m	16mm @ 200mm centres	20mm @ 210mm centres
2.7m	16mm @ 175mm centres	20mm @ 175mm centres
3.0m	16mm @ 150mm centres	20mm @ 150mm centres

Vertical steel shall be carried up as follows:

1. Every first bar: Half the wall height
2. Every second bar: Wall height less 300mm

Horizontal steel shall be 16mm @ 250mm centres (high yield) or 16mm @ 210mm centres (mild steel).

Contraction joints shall be formed by a planned joint in the wall at a maximum of 12m intervals for all walls longer than 16 metres. The joint shall be formed by forming a 12mm x 12mm groove on each face of the wall and reducing the horizontal steel by 50% across the joint. A 200mm patent water bar shall be located at the joint in the centre of the wall and in the wall footing. This water bar shall be kept in position by fixing it to the reinforcement with tying wire as specified by the manufacturer. Care shall be taken in placing concrete to ensure that it is properly compacted around the water bar. The grooves in the finished wall shall be brushed out and sealed with acid resistant mastic in accordance with manufacturers instructions. Care must be exercised in placing concrete around the water bar to ensure that it is not damaged or displaced.

As an alternative to contraction joints the amount of horizontal reinforcing steel shall be increased by at least 50% for the entire wall.

9.2 Roofed walled silo

Table 3 shows reinforcing minima for a cast-in-situ wall forming part of a roofed silo, supported by steel stanchions. [Note: In this design the horizontal steel provides the main strength of the walls.]

Table 3

Wall Height (H)	Horizontal Steel (High Yield)	Horizontal Steel (Mild Steel)	Vertical Steel (HY or MS)
1.8m (min) to 2.4m (max)	12mm @ 150mm centres or 16mm @ 250mm centres	16mm @ 150mm centres	10mm @ 450mm centres

10. Shuttering

Steel shuttering is recommended for silo walls but panels lined with timber may be used. All shutterings must be clean and tight fitting to prevent loss of grout. To maintain cleanliness and facilitate removal they should be oiled lightly with proprietary mould oil prior to each use. Care must be taken that oil does not get onto reinforcing bars and prevent bonding. All shutterings must be properly tied and braced to withstand the pressure of the concrete.

11. Pouring Concrete to Silo Walls

All dirt and debris shall be removed from within the shuttering. Concrete shall be placed in evenly spread layers of not more than 600mm deep. Vibration, by poker vibrator of diameter not less than 50mm shall follow closely on placing. The poker shall be inserted at maximum 400mm centres. It shall be allowed sink under its own weight to the depth of the layer plus 100mm into the layer beneath and when air bubbles cease to rise, be withdrawn slowly but evenly leaving no significant depression in the concrete. Care shall be taken to prevent the vibrator making contact with either the shutters or the reinforcement. Concrete shall not be poured under 4°C in a falling thermometer.

12. Concreting at Horizontal Construction Joint

A layer of water, cement and fine material from the aggregate forms at the top of a lift after the concrete pour. Within an hour or so depending on weather conditions this layer shall be sprayed with water and brushed off with a soft brush to expose the course aggregate. If left overnight it may be necessary to use a stiff brush to clean the surface. The best joints are obtained by light brushing soon after pouring.

13. Removal of Shuttering

Shuttering shall not be removed for at least 12 hours in warm weather, longer in cold weather. Fill all small blemishes caused by removal of bolts and tie bars with 1.5:1 washed sharp sand-cement mortar. All large bolt or tie bar blemishes and honeycombing, if they occur, shall be repaired with a sand: cement mortar incorporating SBR (Styrene Butadiene Rubber) or a water resistant polymer bonding admixture in accordance with manufacturer's instructions.

Note: If good shuttering, properly erected, is used and concrete of proper workability has been well compacted, honeycombing should not occur.

14. Precast Wall

Precast wall systems are acceptable provided such walls are constructed in accordance with Department of Agriculture and Food requirements. They shall require prior Departmental acceptance, and may be subject to requirements for certificates of guarantee. Moveable wall panels are not permitted. All precast walls shall be permanently fixed in place, in the manner specified by the Specialist Unit of the Department of Agriculture and Food for the particular wall panel being used.

Foundations shall be constructed in strict accordance with manufacturers instructions. Standard effluent channels shall be constructed **outside the walls** in all cases. Joints between panels shall be sealed with acid resistant mastic in accordance with manufacturers instructions.

15. Silo Roofs

Roofs and supporting structure shall be constructed in accordance with S101. In the case of heavy duty walls reinforced in accordance with Table 3, Clause 6, steel reinforcing and Figures 4A and 4B, the following modification to S101 shall be made:- Stanchion size, for spans less than 9.6m, shall be 203mm x 102mm RSJ @ 25.3kg/m or IPE 220 @ 26.2kg/m (220mm x 110mm). The stanchion foundation shall be 1.35m x 600mm x 600mm as shown on Figures 4A and 4B.

16. Thickness of Concrete Floor Slab

The thickness of the concrete slab shall be as shown on the detailed drawing but at no place shall it be less than 125mm. Under channels the concrete shall be thickened to at least 150mm below the invert level of the channels as shown (Figs. 5, 6 & 7).

17. Channels

The front of the silo floor shall have a recessed channel to convey the effluent to an approved effluent tank. The channel shown in Figure 5, incorporating timber or

concrete block inserts, is strongly recommended. The channel shown in figure 6 is also allowed. The channel shown in Figure 7 is for the side of the apron. If the rear wall is omitted, a channel shall be constructed across both ends of the silo to convey the effluent to an approved effluent tank. Care shall be taken when forming the channels to ensure that adequate depth and fall is maintained during construction and that a minimum 150mm depth of concrete is maintained beneath the channel invert level in all circumstances.

A similar channel along each side of the silo parallel with the silo wall but **on the slab inside the wall footing (at least 1.2m from the wall)** may also be provided.

18. Concrete to Floor Slab

Concrete to silo floor slab shall be laid on 1000 gauge polythene membrane (lapped 600mm at joints and taped) on prepared hardcore base specified in Clause 4. The concrete shall be laid in alternate bays measuring not more than 4.5m wide by 6m long to slope of 1:60, see Fig. 8. Concrete should be allowed to harden for at least 2 days before the remaining bays are poured. The edges of the slabs (except where the slab abuts an existing bay or silo wall) shall be supported by strong shuttering, set to the correct level. The concrete should be placed about 20mm proud of the shuttering and then tamped down to the correct level using a vibrating screed. Particular care should be taken to compact the concrete near edges and joints, preferably with a poker vibrator.

Joints between alternate bays should have a 25mm x 12mm recess preformed by the shuttering, see Fig. 3. This joint to be brushed out and filled with acid resistant mastic sealant. Alternatively, where concrete base is laid in one operation, joints (in bays not exceeding 6m x 4.5m) shall be cut by disc-cutter to a depth of 30mm and to a full 12mm width formed by a double cut in the hardened concrete within 24 hours of placing. These joints shall be brushed out and filled when dry with acid resistant mastic sealant installed in strict compliance with the manufacturer's instructions. Extra care shall be taken that joints running across effluent channels are completely sealed. The junction of floor and wall shall be treated as a joint.

If it is thought necessary to strengthen the slab for any reason, A 142 steel mesh may be installed 50mm above the bottom of the slab. In all cases construction joints shall be formed.

19. Silage Aprons

A silage apron shall be constructed at the front of a walled silo, for the full width of the silo. The silage apron will normally extend 8m from the front of the silo and may be up to 10m, but shall not be less than 6m. The apron shall be constructed to the same standard as the silo base. The apron shall be cast at the same time as the silo floor.

Silage Aprons shall normally have channels at the side and at the front edge (Figs. 8 & 10). If the Apron has no front-channel, then the apron shall slope back towards the front channel of the silage base. The minimum slope of the apron in this case shall be 1 in 40. In all cases the apron shall have channels along its sides.

It is recommended that a channel be constructed along the back of the apron, forming a double channel (see Fig 10) so that rain falling on the apron can be separated from the silage effluent on the main base.

20. Effluent Disposal

Silage effluent has a very high polluting potential. To facilitate efficient and rapid drainage of the effluent, it is recommended a 70mm land drainage pipe be placed in the channels in the silo if such channels are provided. If channels are not provided, it is recommended that land drainage pipes be laid along the junction of walls with the floor, terminating in the effluent-collecting channel.

Where a diversion system for clean water runoff is constructed (Fig. 9), pipe joints shall be carefully constructed and shall be watertight. All effluent or soiled water shall be collected in an approved effluent tank or other approved storage facility and only clean water runoff shall be diverted from the storage facility. The flow directions shall be designed so that if diversion plugs (which shall extend at least 500mm up from the finished base level when in place) are missing or damaged, the effluent shall flow to the storage facility.

Note: Where silage effluent is allowed into a slurry tank the effluent shall discharge via a pipe at least 300mm from the inner face of the tank wall.

21. Safety Rail

A horizontal guide rail of 50mm medium gauge tubular steel, or box iron or 50mm x 6mm thick angle iron shall be fixed 1m over the top of all silo walls. The rail shall be supported at 1.5m centres with the same section steel either grouted into the wall or rail bolted to the wall. The purpose of this guide rail is to indicate the location of the wall during silage making and to provide protection to workers while covering the silage.

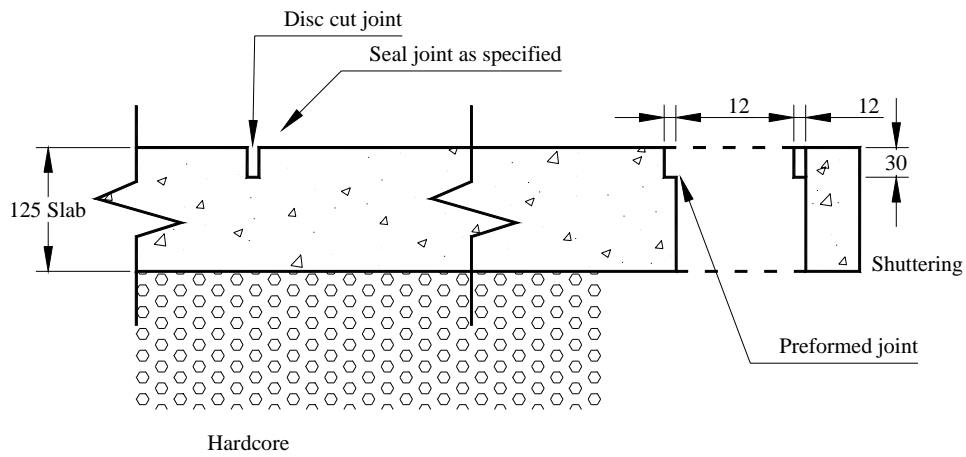

Figure 3 Details of Floor Joint

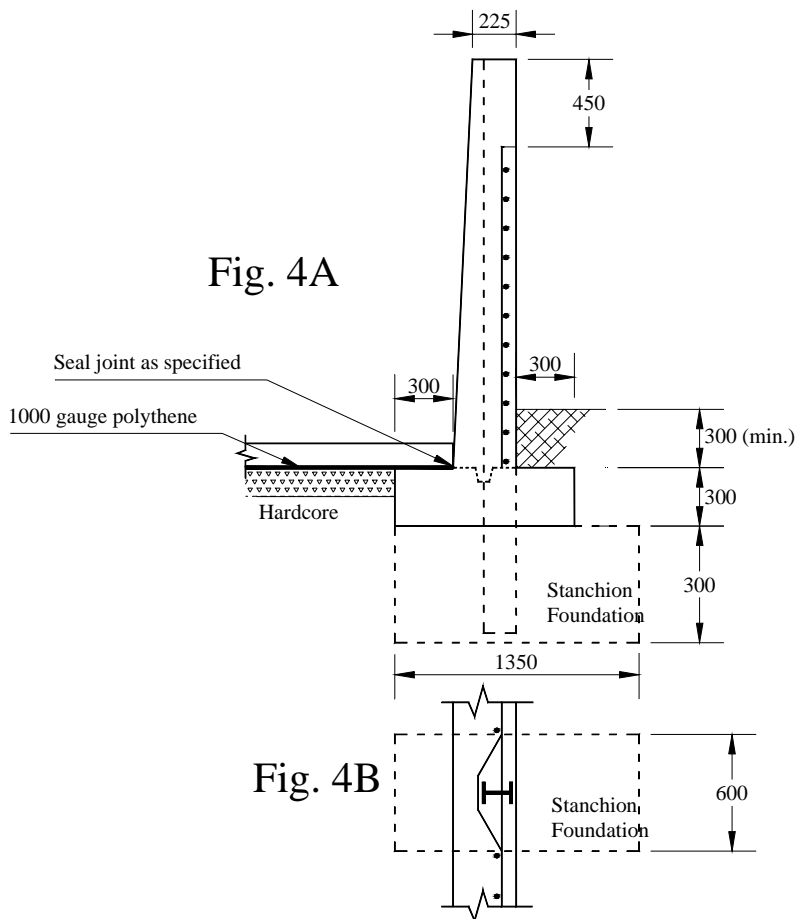

Figure 4 Reinforced Wall for Roofed Silo

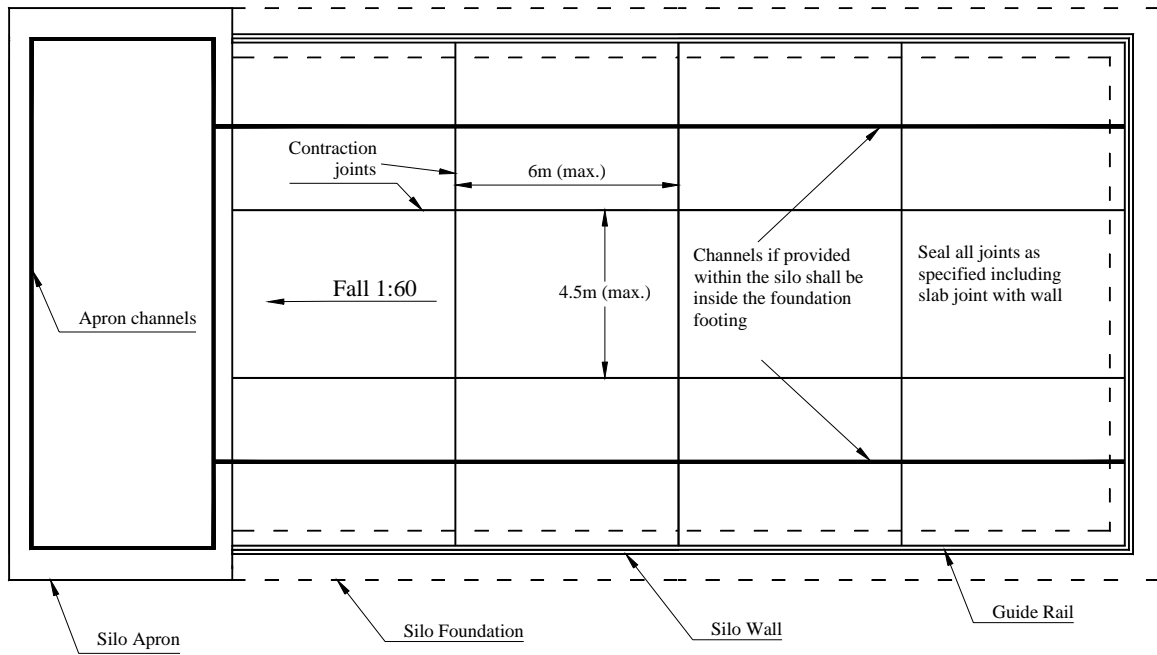

Figure 8: Plan of walled silo

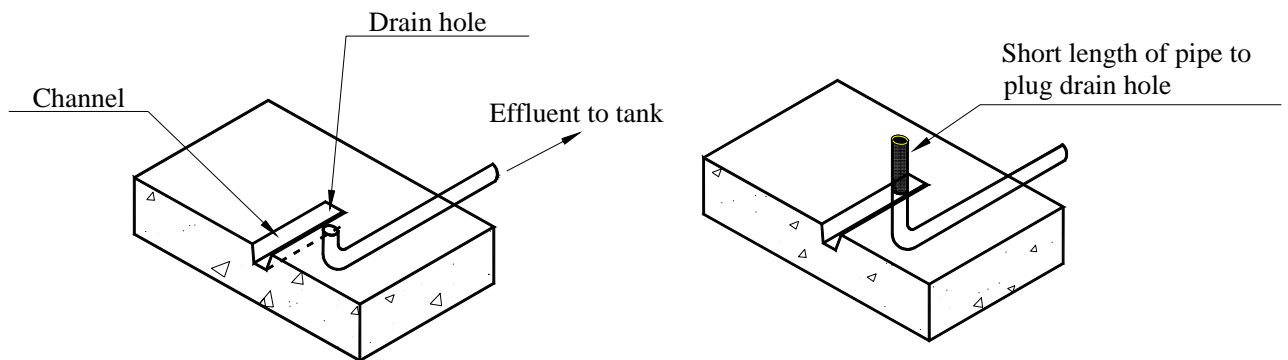

Figure 9: Diversion system

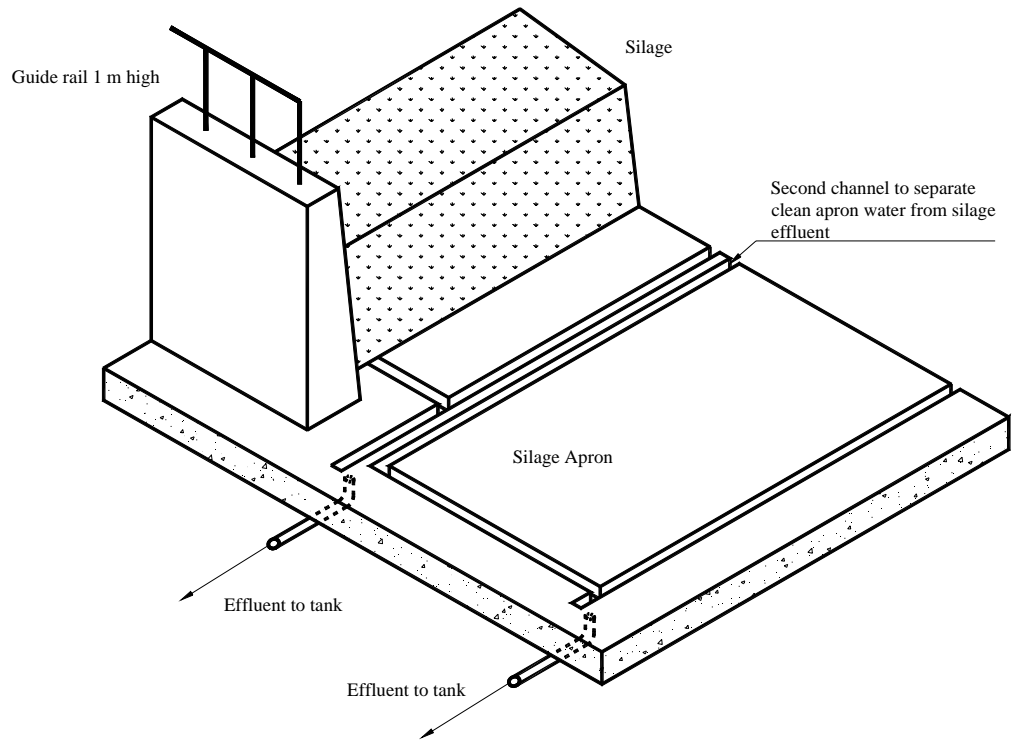

Figure 10